

PAPER CRAFT

<http://www.canon.com/c-park/en/>

sheet-1



● View of complete model (Front view)



● View of complete model (Front view)



● View of complete model (Side view)



● View of complete model (Back view)

JAGUAR MkII SALOON

The "Jaguar- MkII SALOON" is a compact saloon from Jaguar, which made its debut in 1959 at an automobile show in London. The model featured an original styling, its four-door body designed with a sleek, streamlined finish. It also made use of sash-type doors and windows, considered innovative at the time. The Jaguar-MkII SALOON came in 2.4, 3.2, and 3.8 liter types, each featuring a straight-six DOHC engine. As for the vehicle's suspension, the front sported a double wishbone suspension while the rear had a rigid axle suspension. Furthermore, disc brakes were installed on all four wheels. Equipped with a high-powered engine, excellent suspension, and powerful brakes, the Jaguar-MkII has also participated in touring car championships and rallies. While its great performance led it to be known as the best sporty saloon at the time, it was also the core model produced by Jaguar up until 1967.

This Papercraft Jaguar-MkII SALOON is about one thirteenth the size of the real car.

*This model was designed for Papercraft and may differ from the original in some respects.

■ Parts list (Pattern) : Fourteen A4 sheets (No.1 ~ No.14)

■ No. of Parts: 154

*Build the model by carefully reading the Assembly Instructions, in the parts sheet page order.

sheet-2

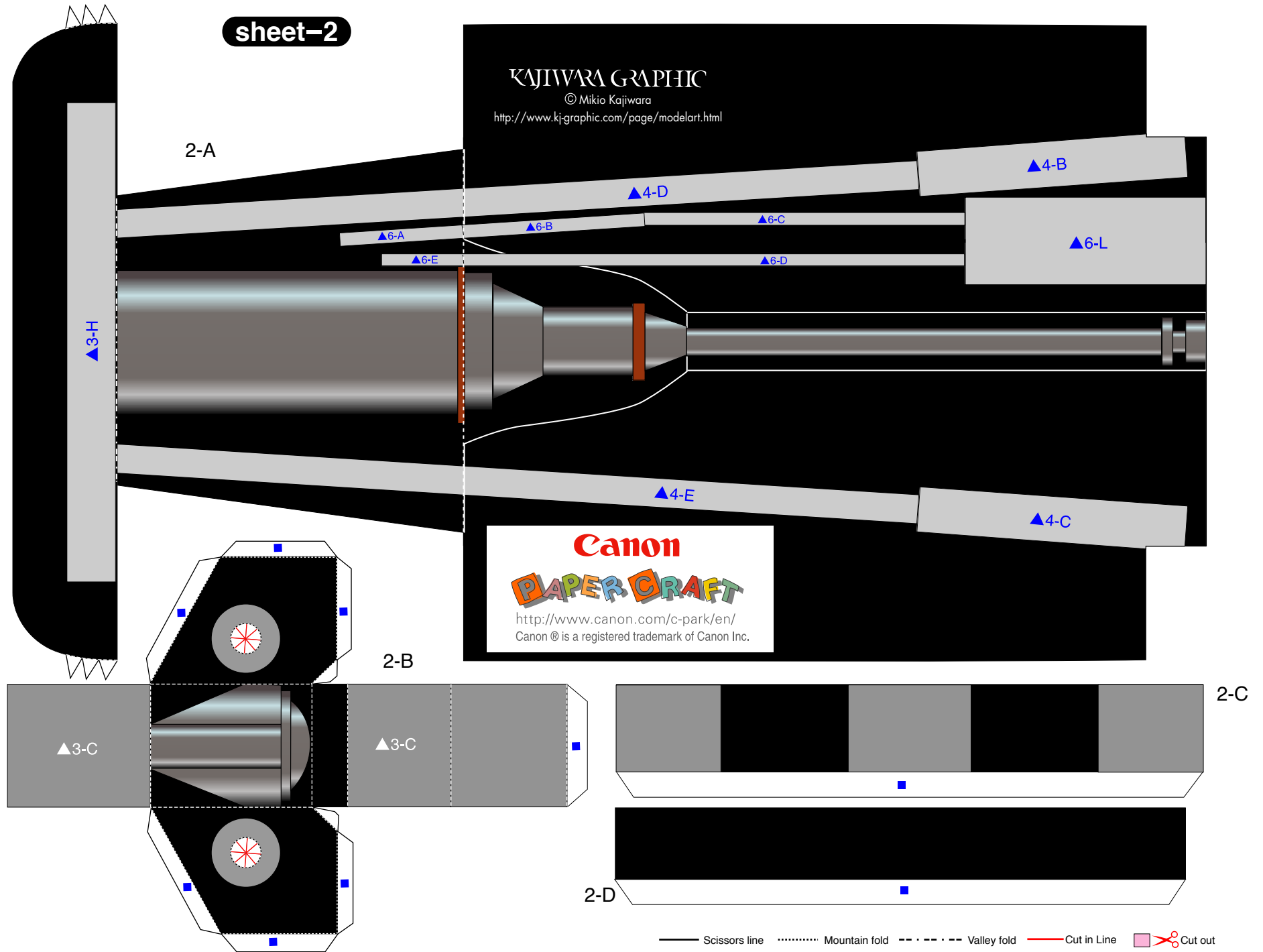

sheet-3

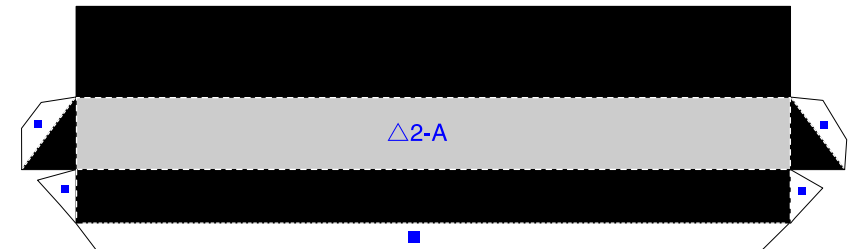
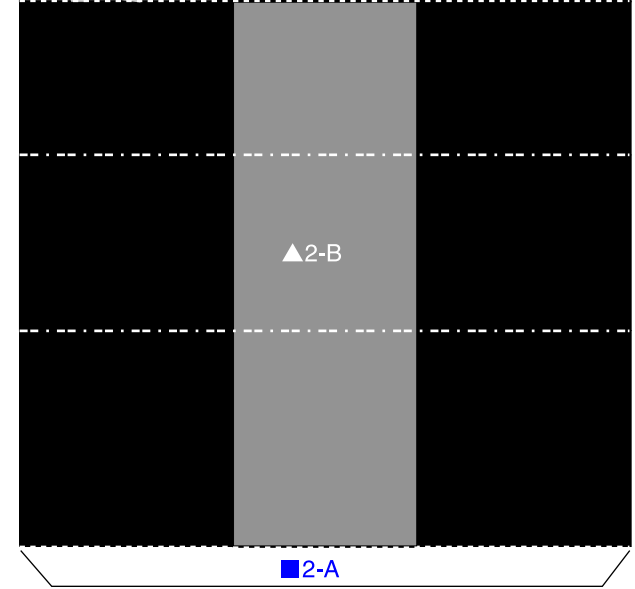
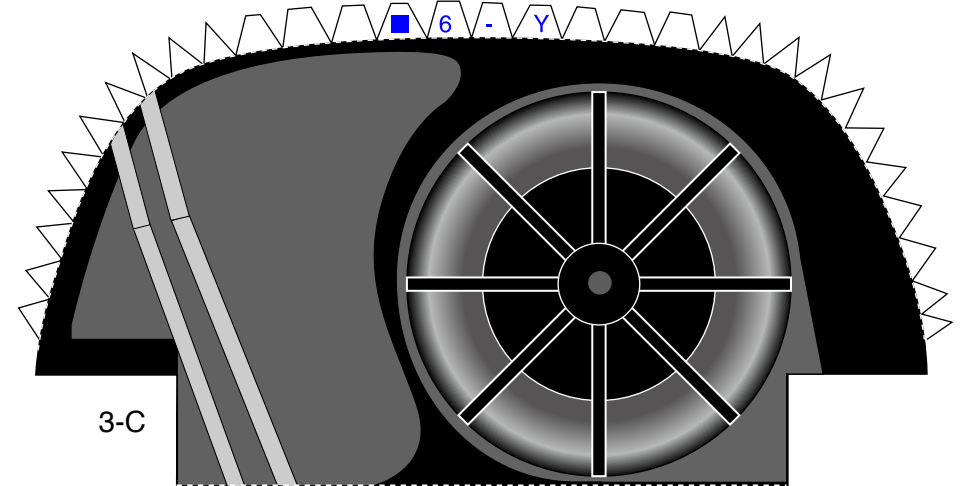
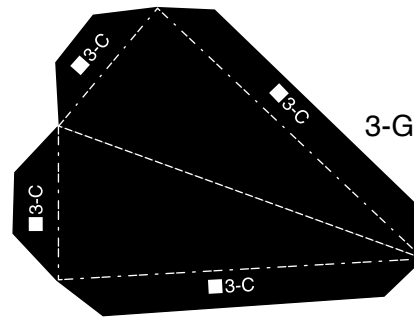
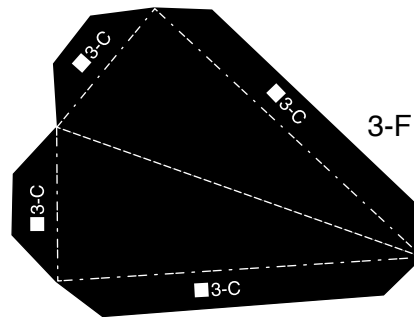
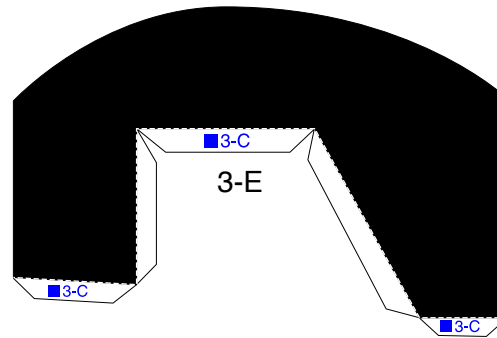
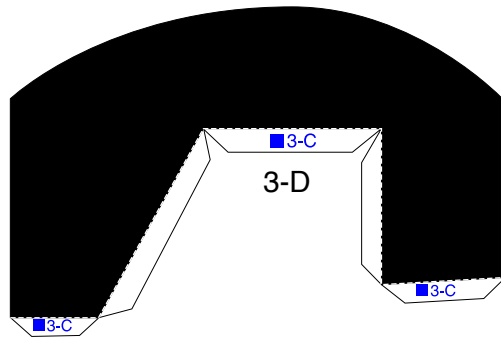
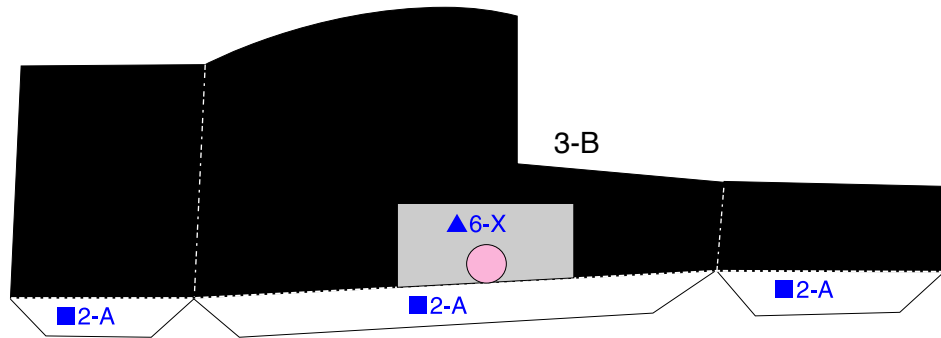
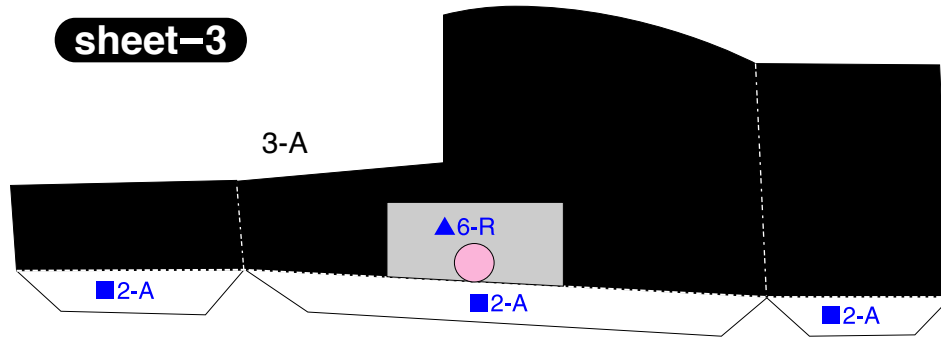

sheet-4

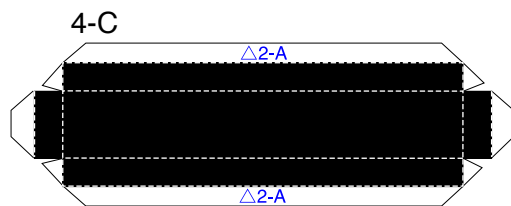
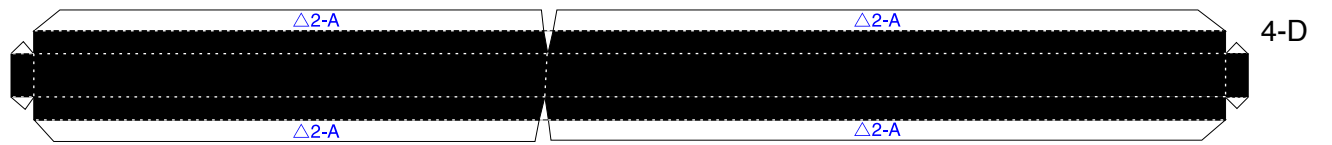
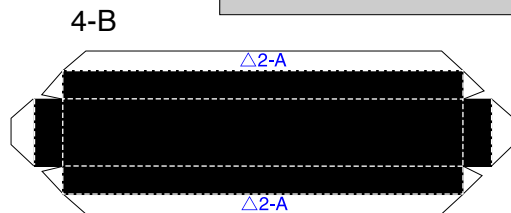
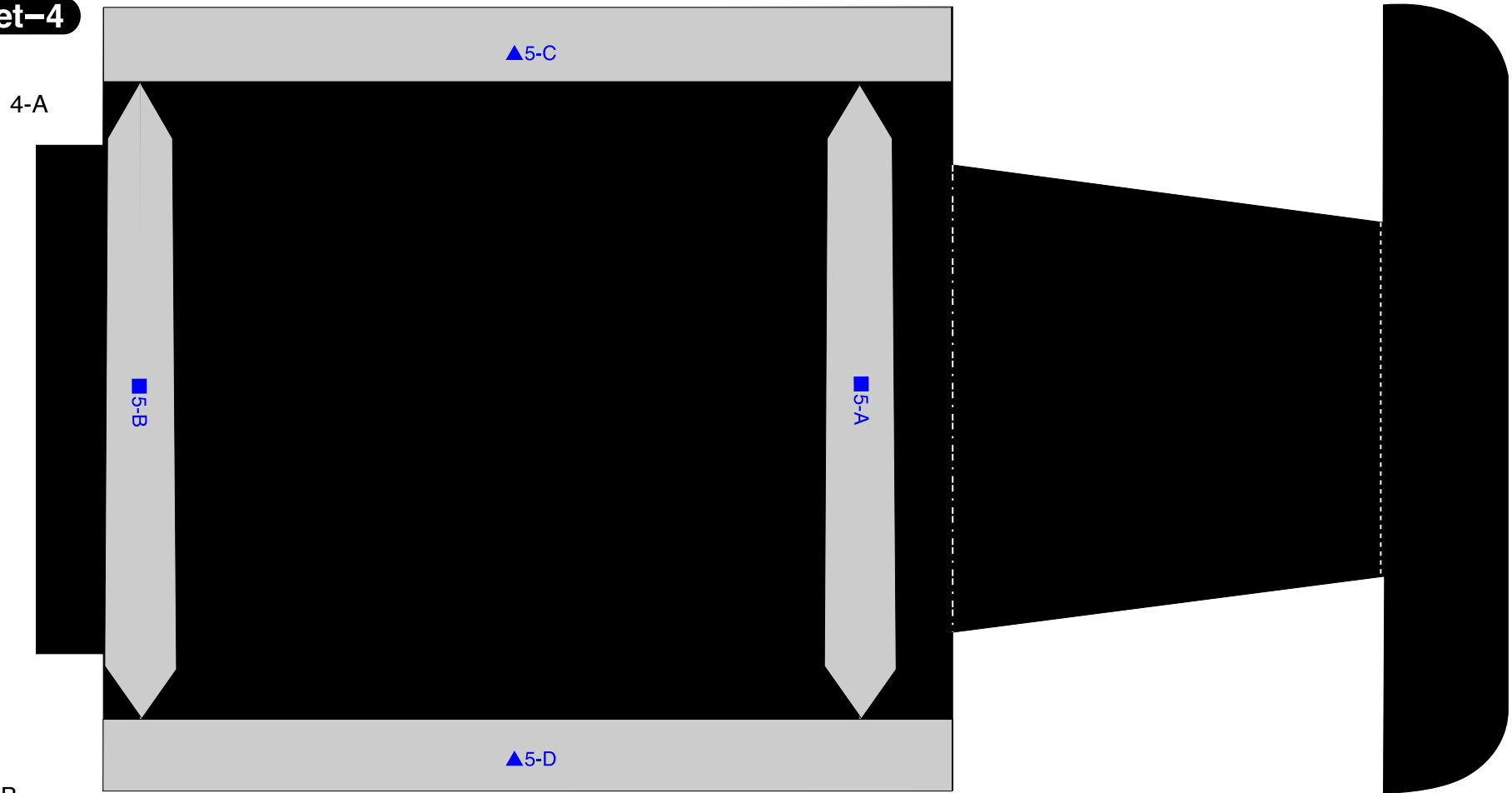

— Scissors line ····· Mountain fold - - - - - Valley fold — Cut in Line ✂ Cut out

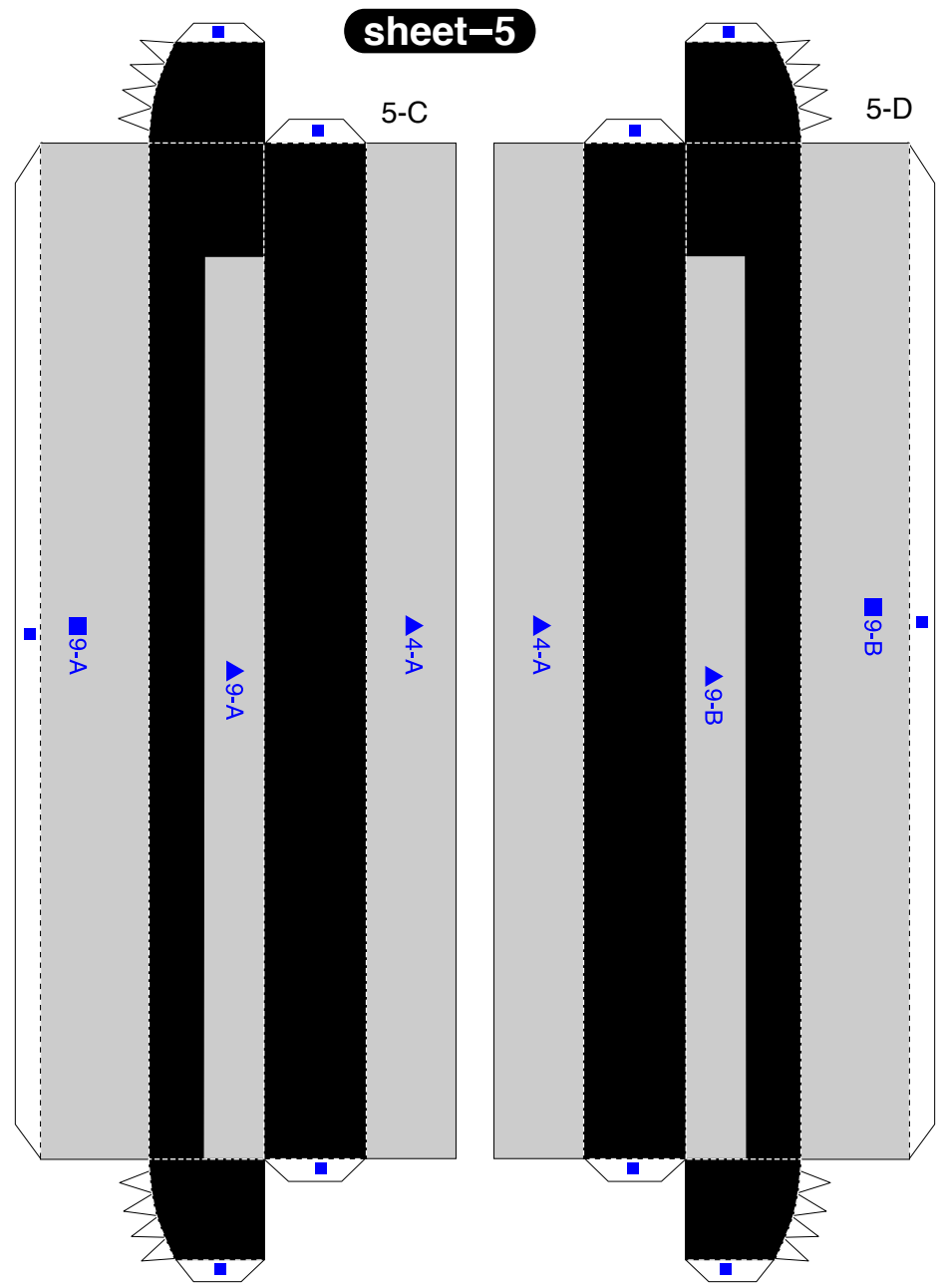
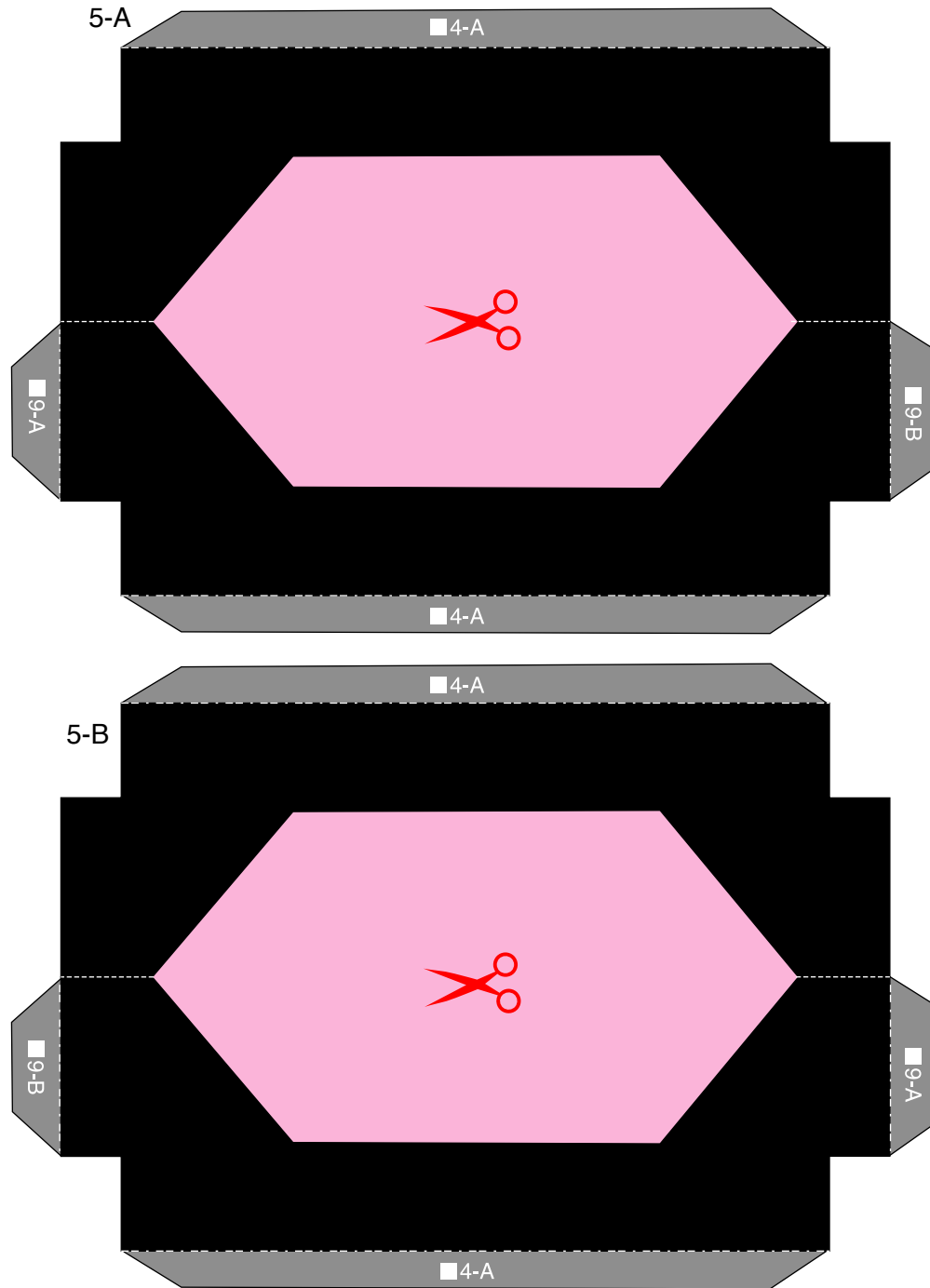

sheet-5

sheet-6

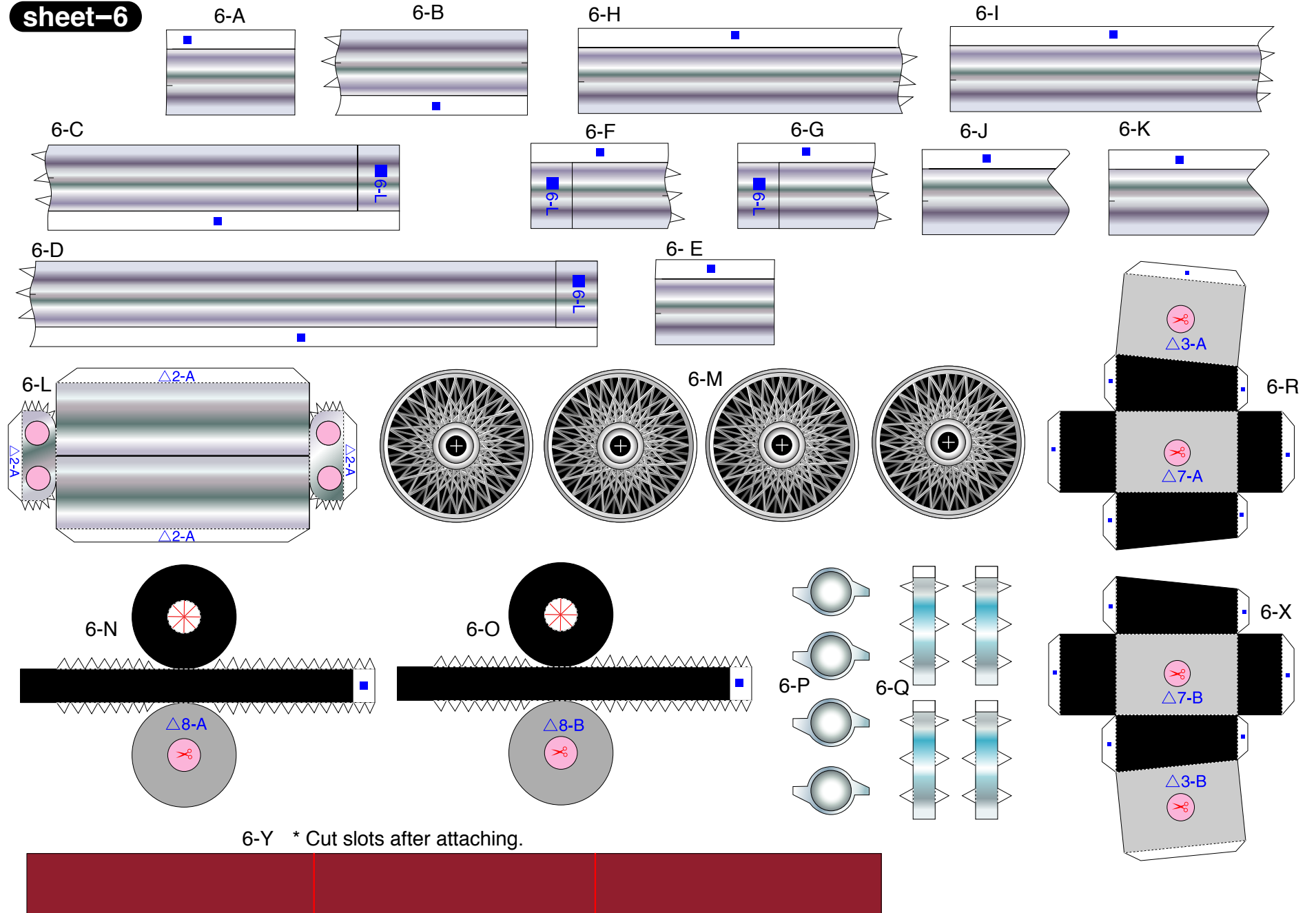

sheet-7

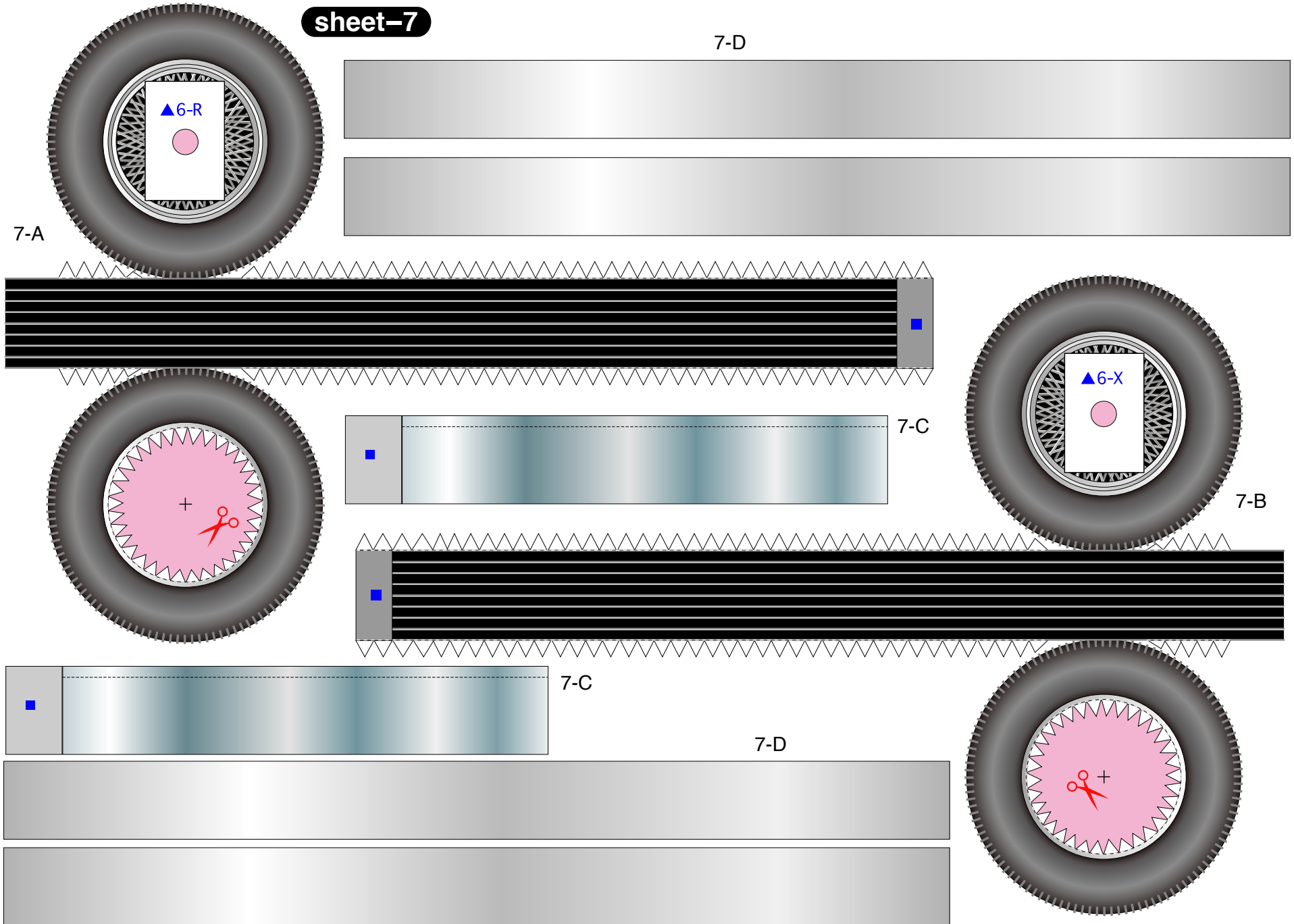

sheet-8

8-D

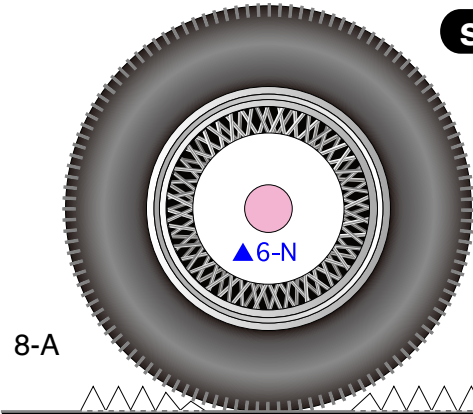

8-A

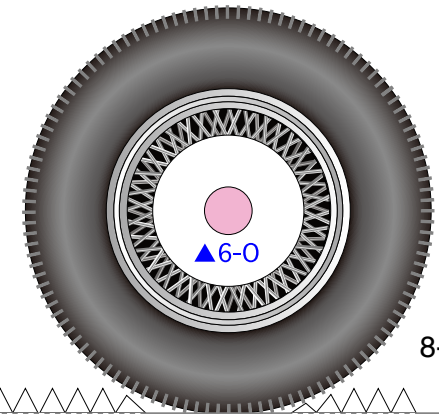
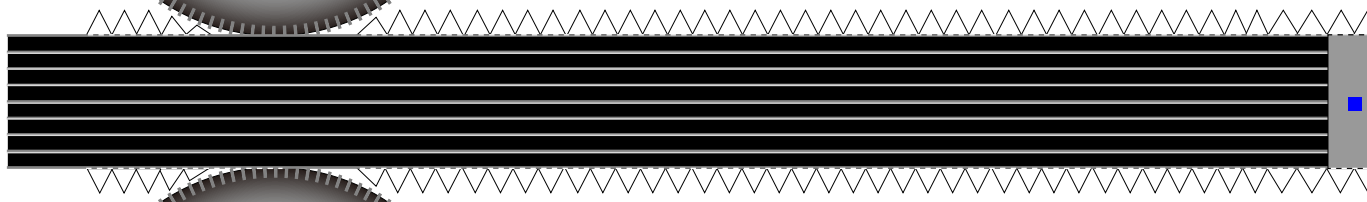

8-B

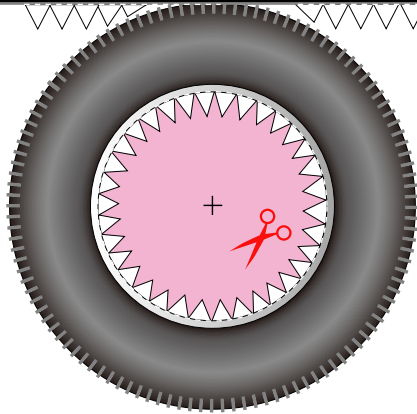

8-C

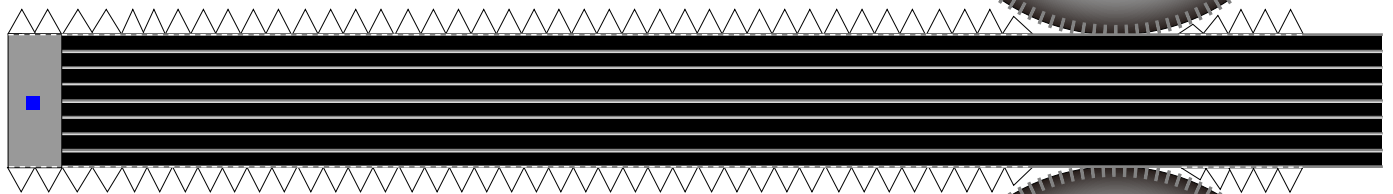

8-C

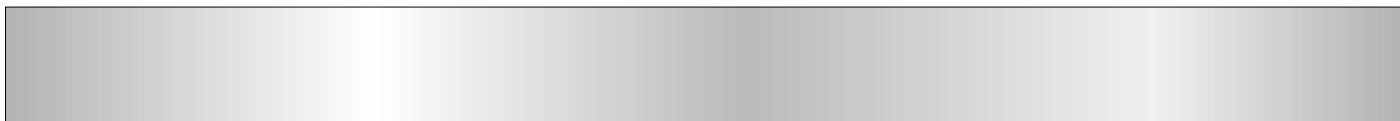

8-D

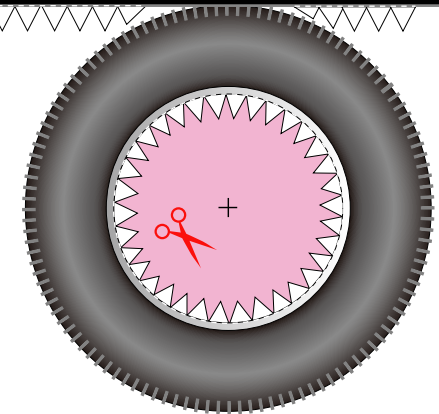

sheet-9

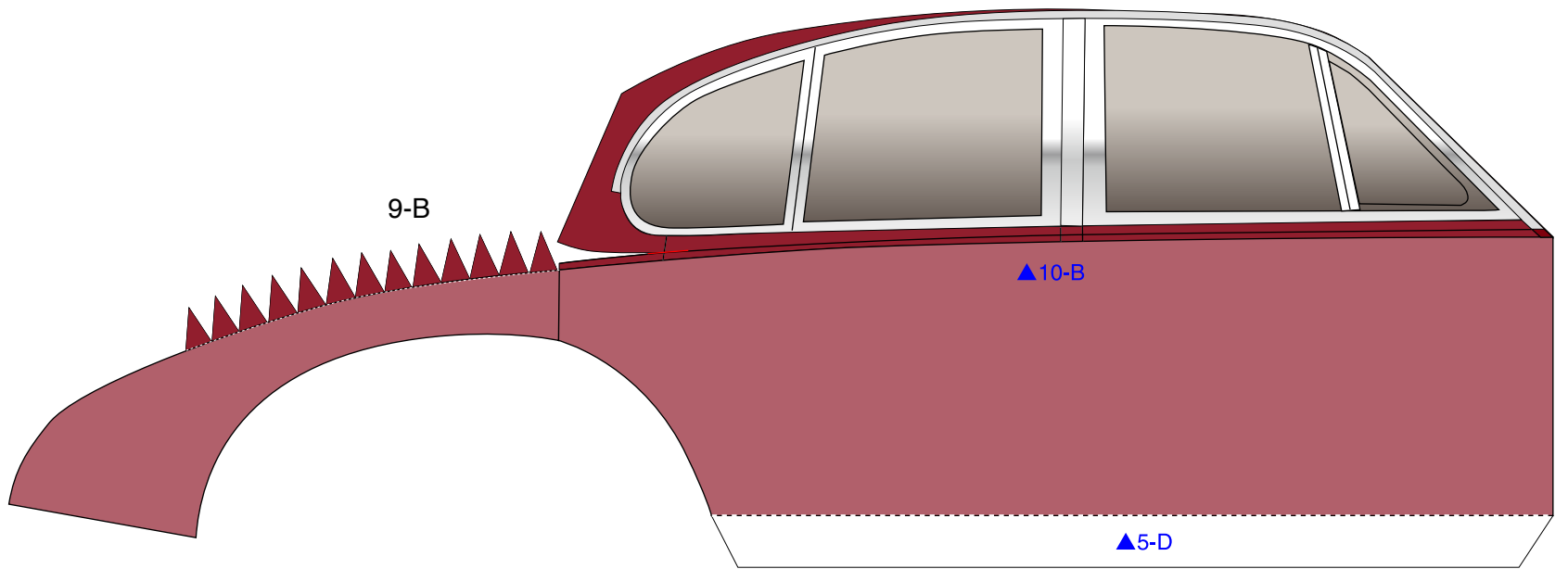
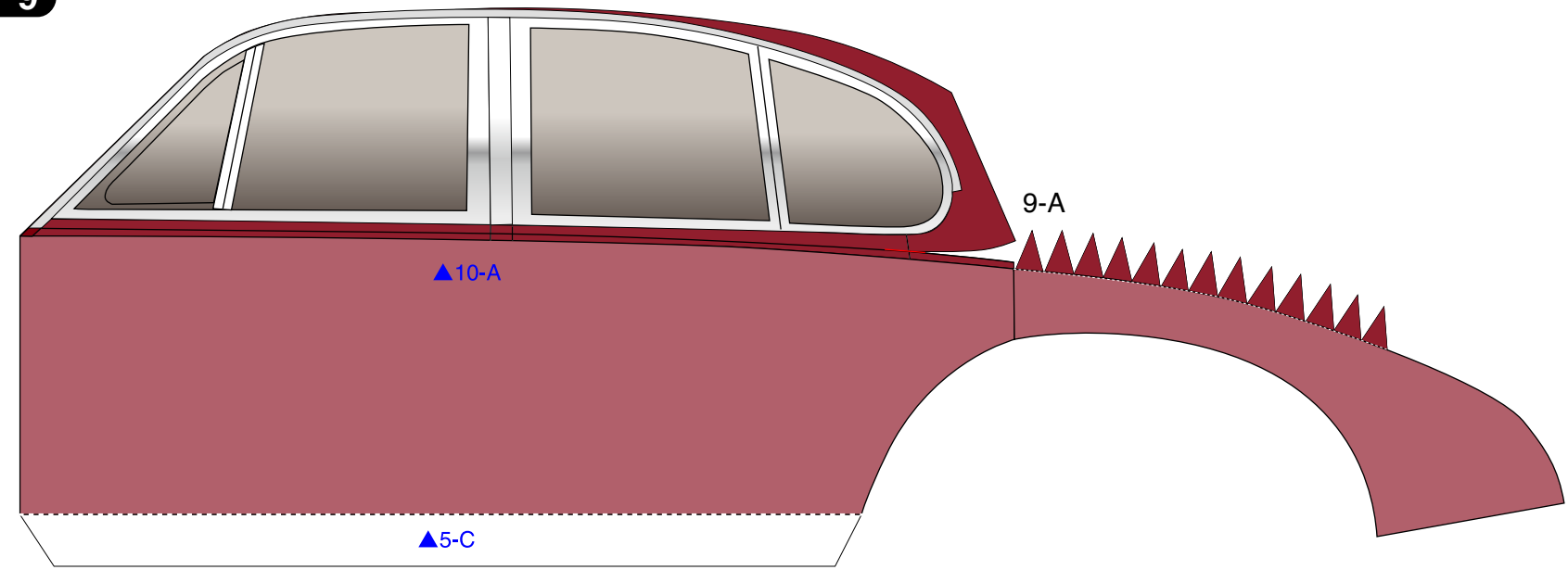

sheet-10

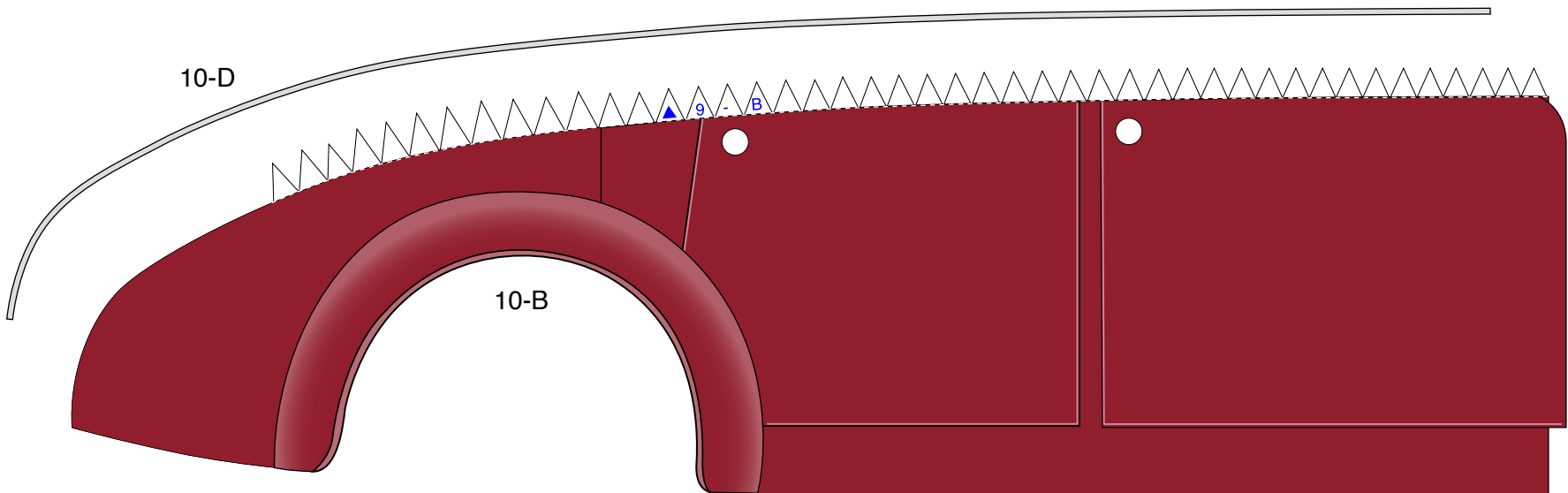
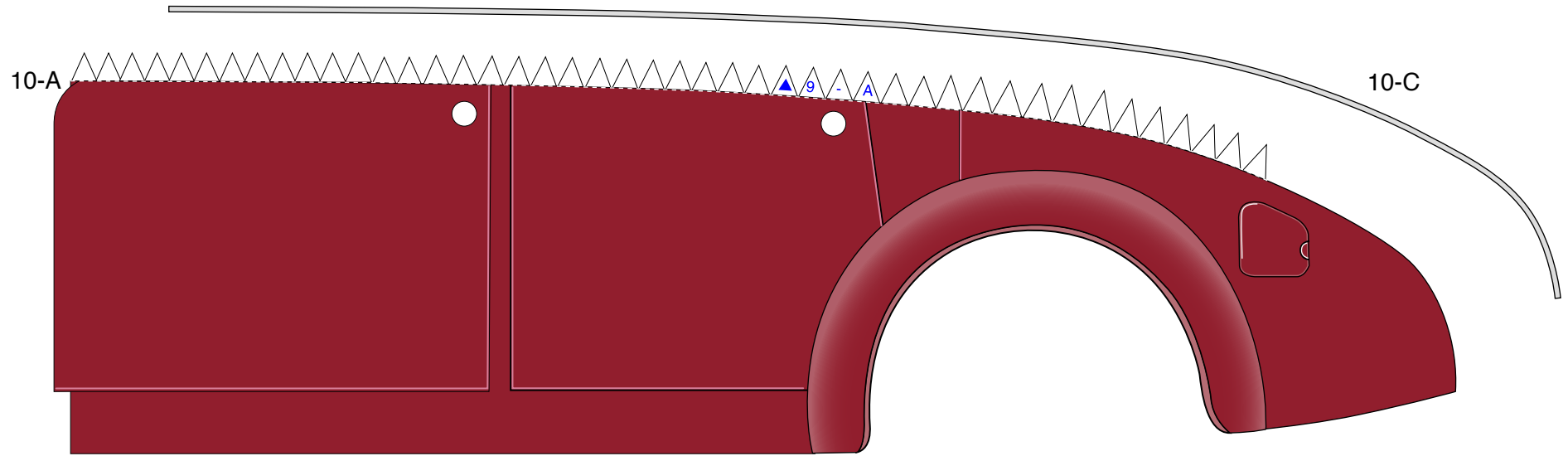

sheet-11

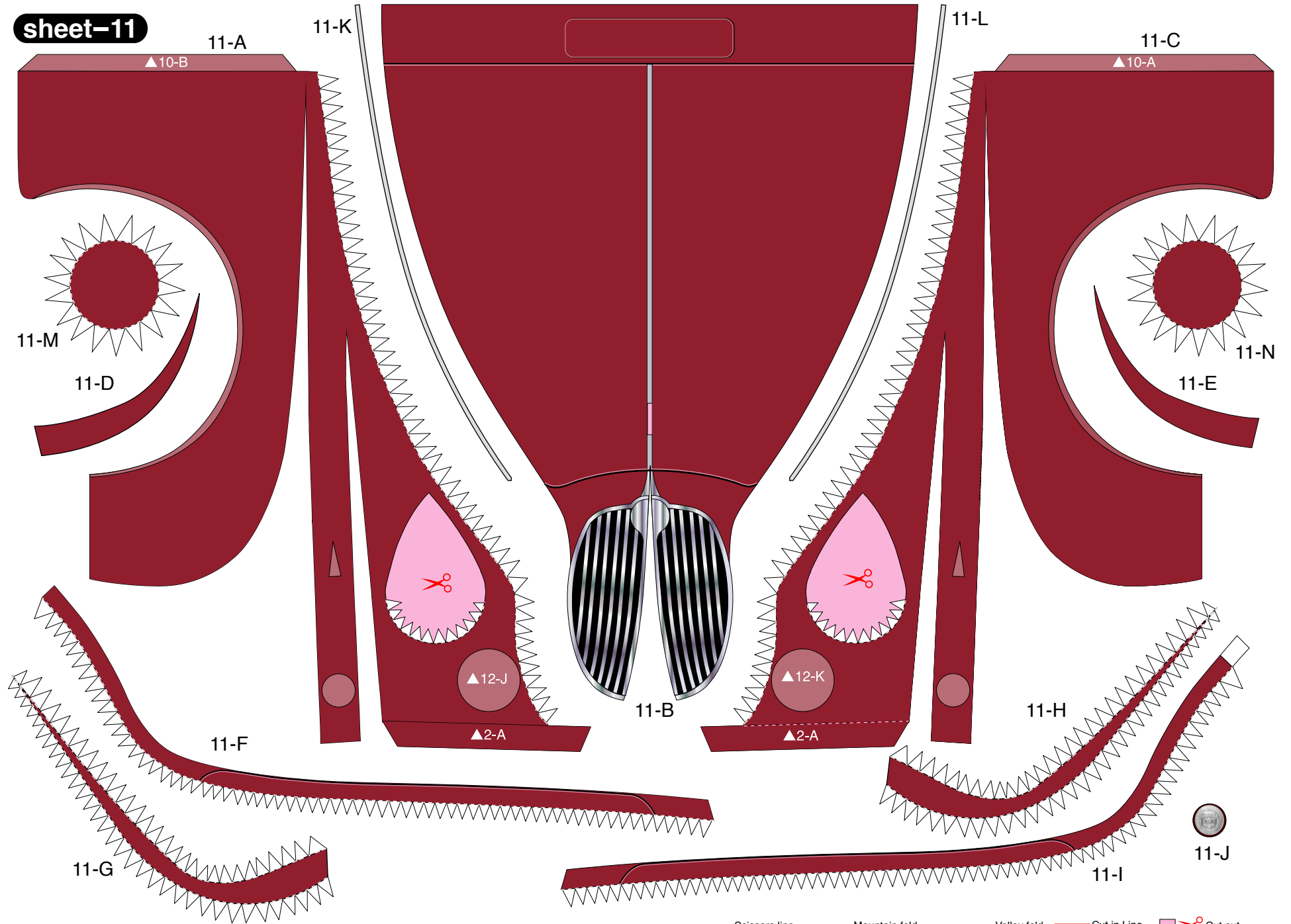

Scissors line
 Mountain fold
 Valley fold
 Cut in Line
 Cut out

sheet-12

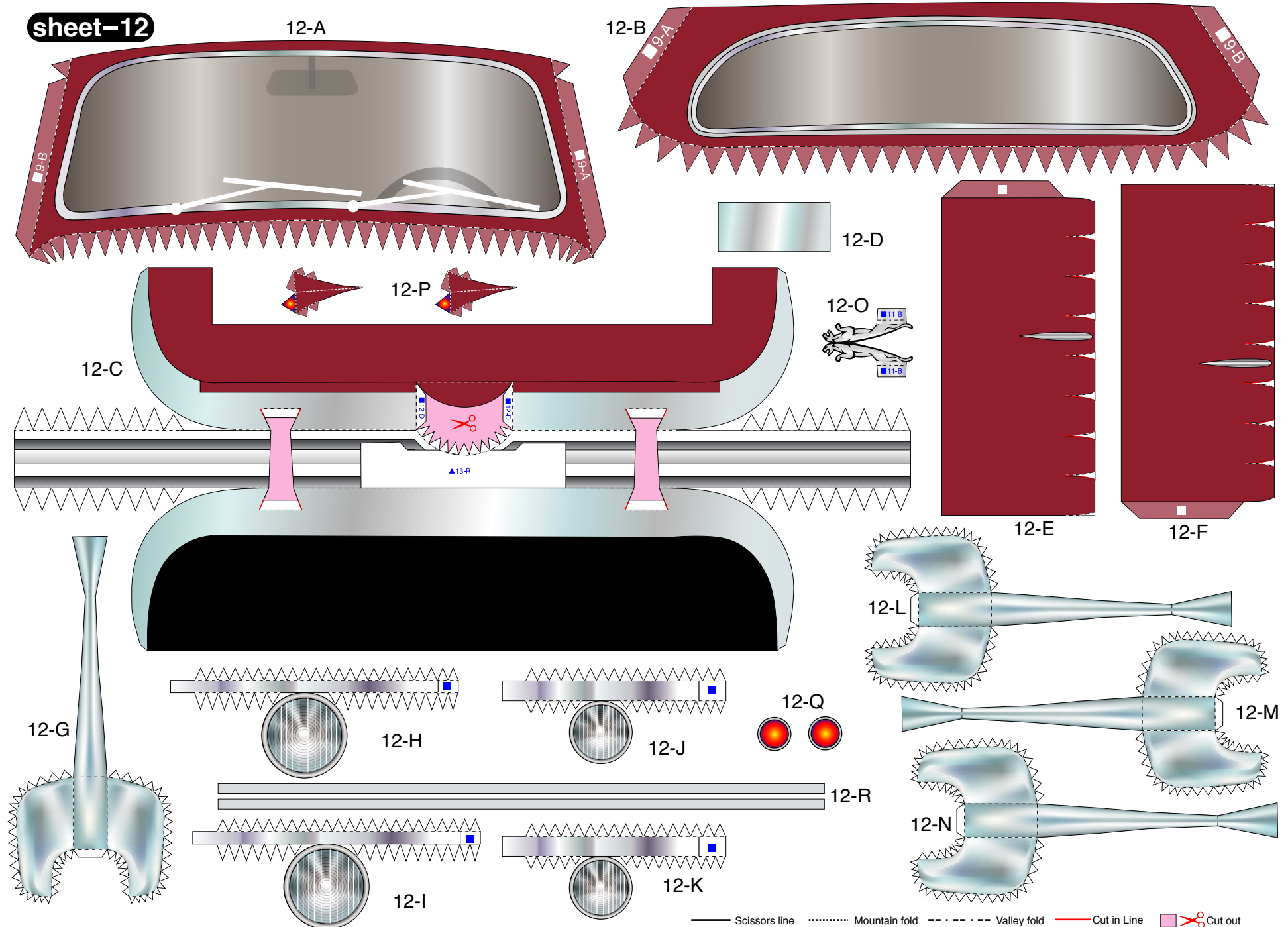

— Scissors line Mountain fold - - - - - Valley fold — Cut in Line Cut out

sheet-13

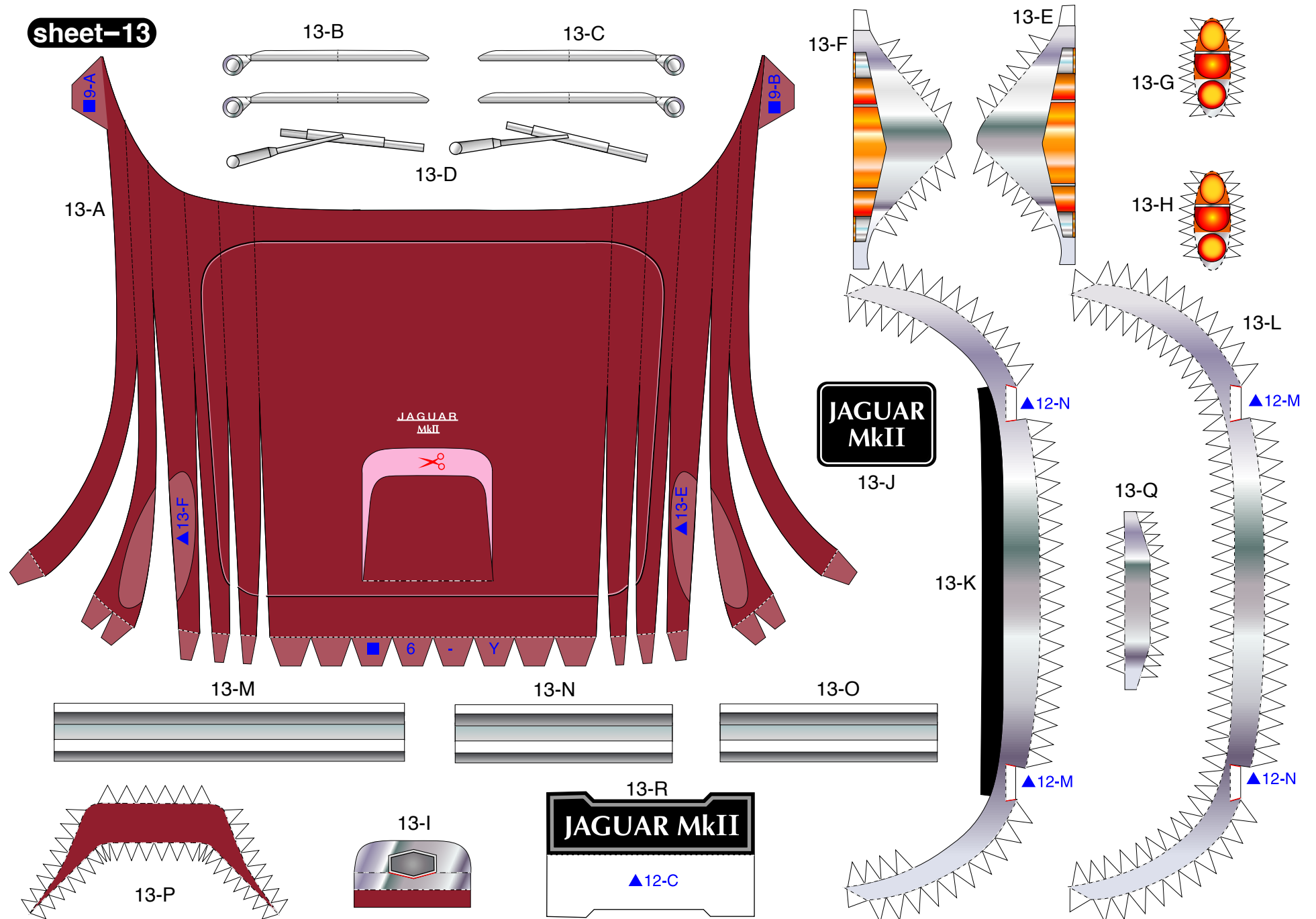

— Scissors line Mountain fold - - - - - Valley fold — Cut in Line Cut out

sheet-14

14-A



14-B

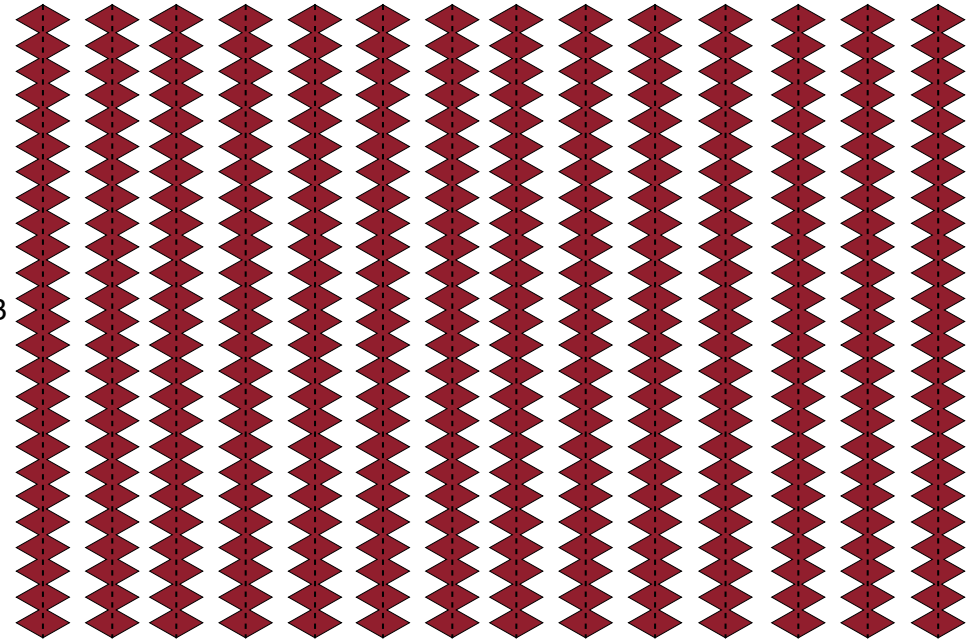

For use as glue tabs

14-B

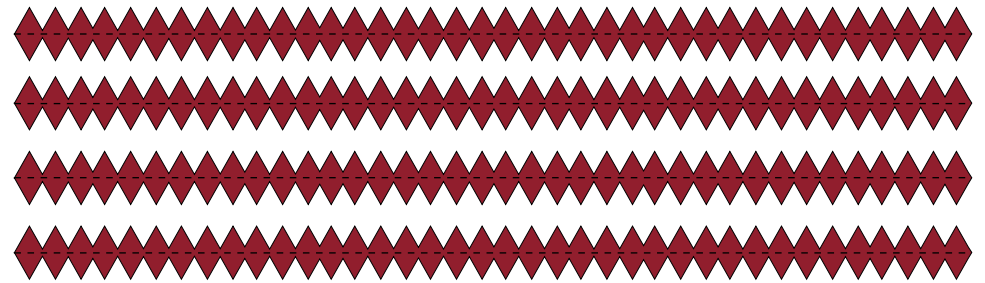

14-B

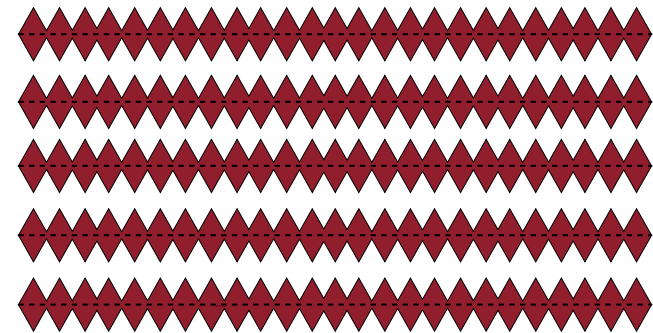

14-B

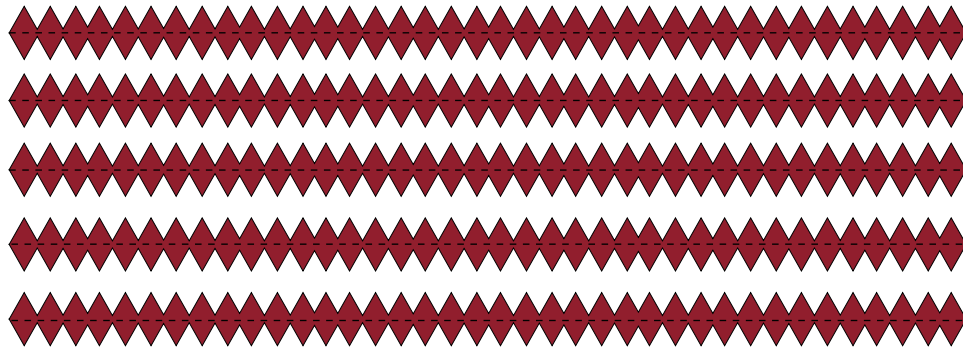



<http://www.canon.com/c-park/en/>



● View of complete model (Front view)



● View of complete model (Side view)



● View of complete model (Back view)

JAGUAR MkII SALOON

The "Jaguar- MkII SALOON" is a compact saloon from Jaguar, which made its debut in 1959 at an automobile show in London. The model featured an original styling, its four-door body designed with a sleek, streamlined finish. It also made use of sash-type doors and windows, considered innovative at the time. The Jaguar-MkII SALOON came in 2.4, 3.2, and 3.8 liter types, each featuring a straight-six DOHC engine. As for the vehicle's suspension, the front sported a double wishbone suspension while the rear had a rigid axle suspension. Furthermore, disc brakes were installed on all four wheels. Equipped with a high-powered engine, excellent suspension, and powerful brakes, the Jaguar-MkII has also participated in touring car championships and rallies. While its great performance led it to be known as the best sporty saloon at the time, it was also the core model produced by Jaguar up until 1967.

This Papercraft Jaguar-MkII SALOON is about one thirteenth the size of the real car.

*This model was designed for Papercraft and may differ from the original in some respects.

■ Parts list (Assembly Instructions) : Twelve A4 sheets (No.1 ~ No.12)

■ No. of Parts: 154

*Build the model by carefully reading the Assembly Instructions, in the parts sheet page order.

Assembly Instructions



Mountain fold

● Make a Mountain fold



Scissors line

● Cut along the line



Valley fold

● Make a Valley fold



Cut in Line

● Cut along the red solid line



Completed parts become a cylinder



Layer wrapping (roll)

Wrap around and glue to the cylinder, to use as a glue tab



Wrap around and glue to the top of the cylinder.

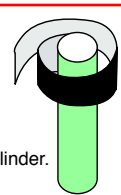

How to make the cylinders

This craft involves making cylinders with diameters of 3 to 7mm, so it may be helpful to have some rods of sizes about 0.5mm thinner handy.

Guide rod



Trace along the folds with a ruler and a used pen (no ink) to get a sharper, easier fold.

Glue, scissors and other tools may be dangerous to young children so be sure to keep them out of the reach of young children.

Glue tab notation key

Each glue tab has a symbol and number printed on it. △marks surfaces to put glue on; they should then be glued to the corresponding ▲.



▲ Apply glue here



△ Attach here



Glue to the rear of the other part

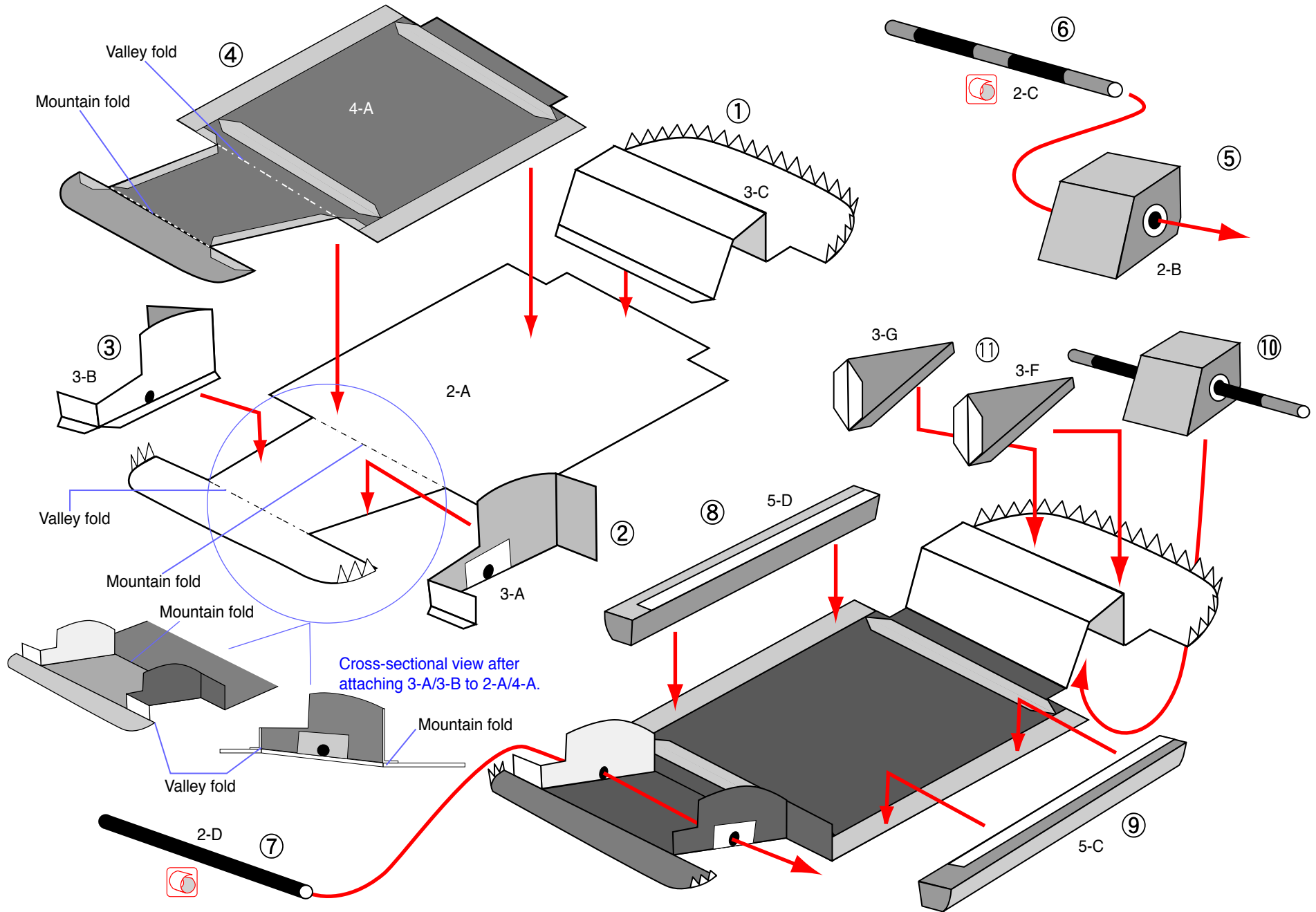

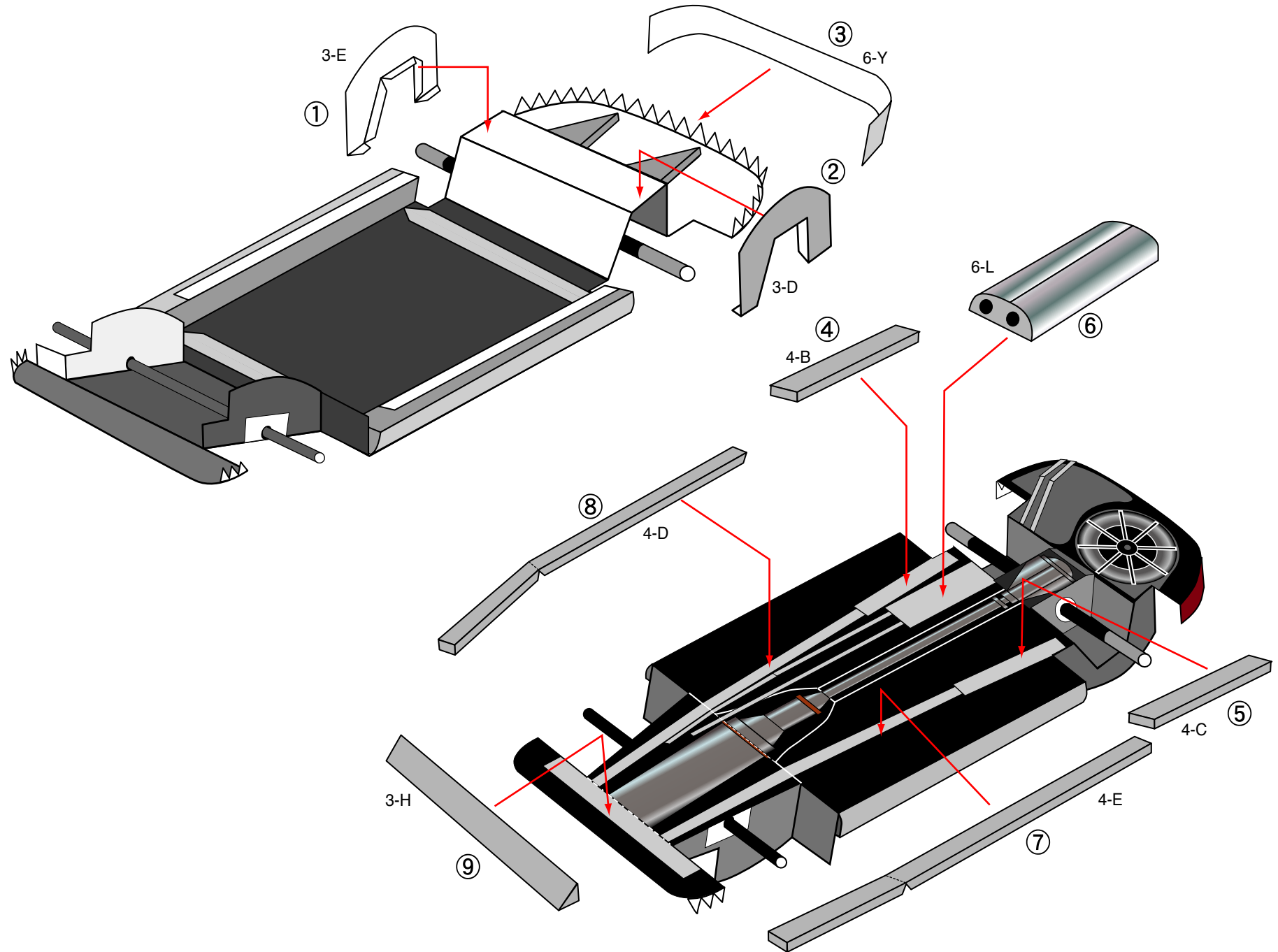

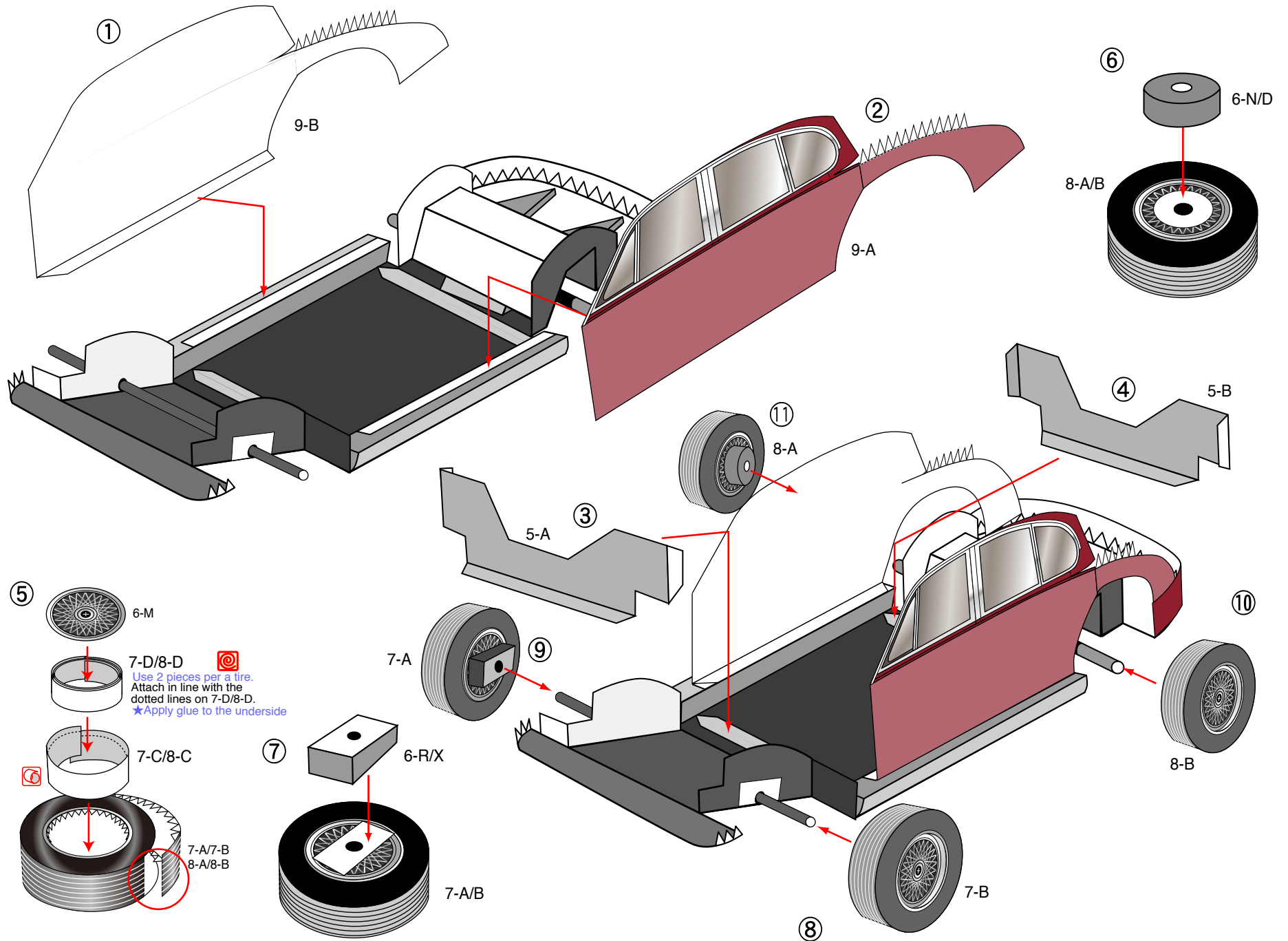

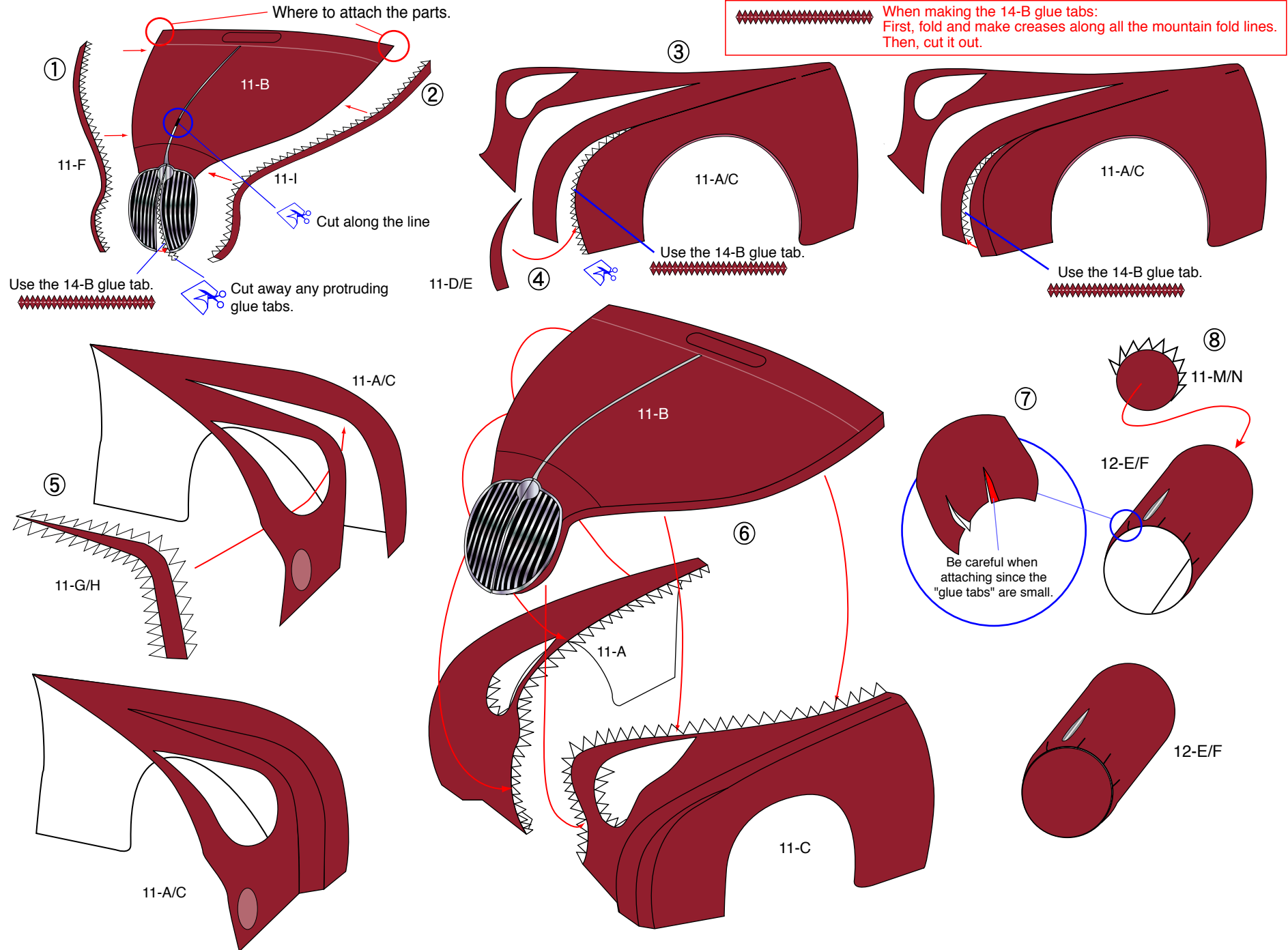

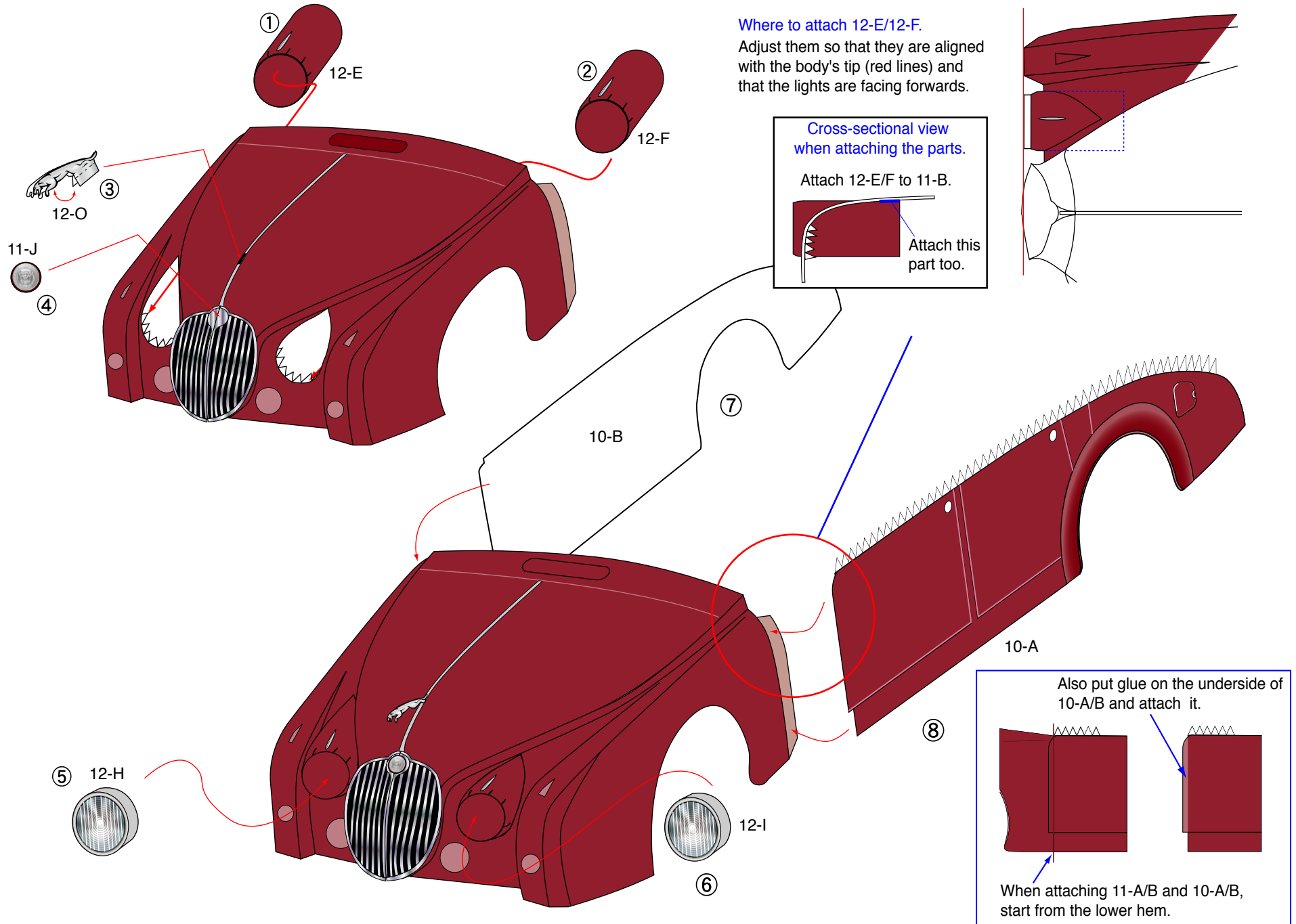

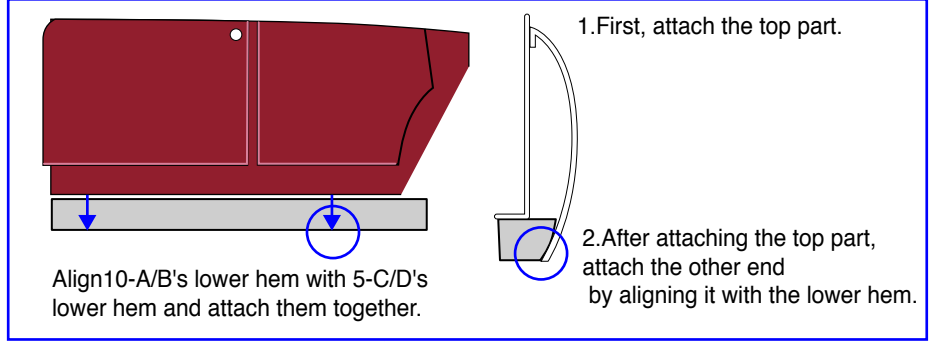
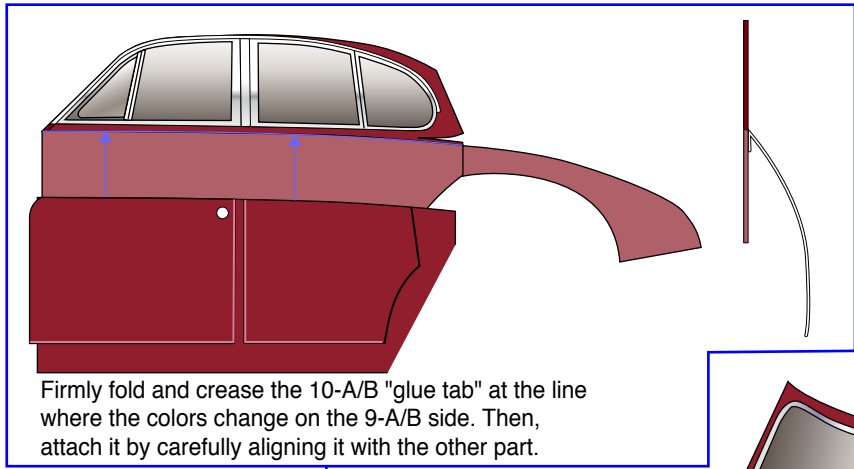

Firmly fold and crease the 10-A/B "glue tab" at the line where the colors change on the 9-A/B side. Then, attach it by carefully aligning it with the other part.

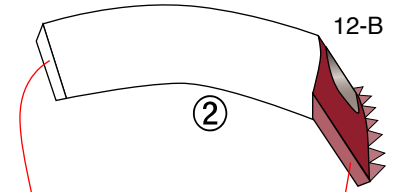
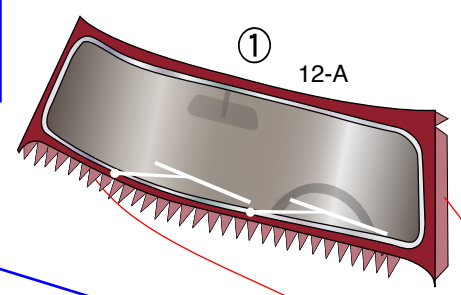

③ When attaching the body, start from the door (see circled area).

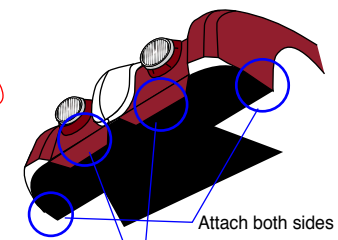
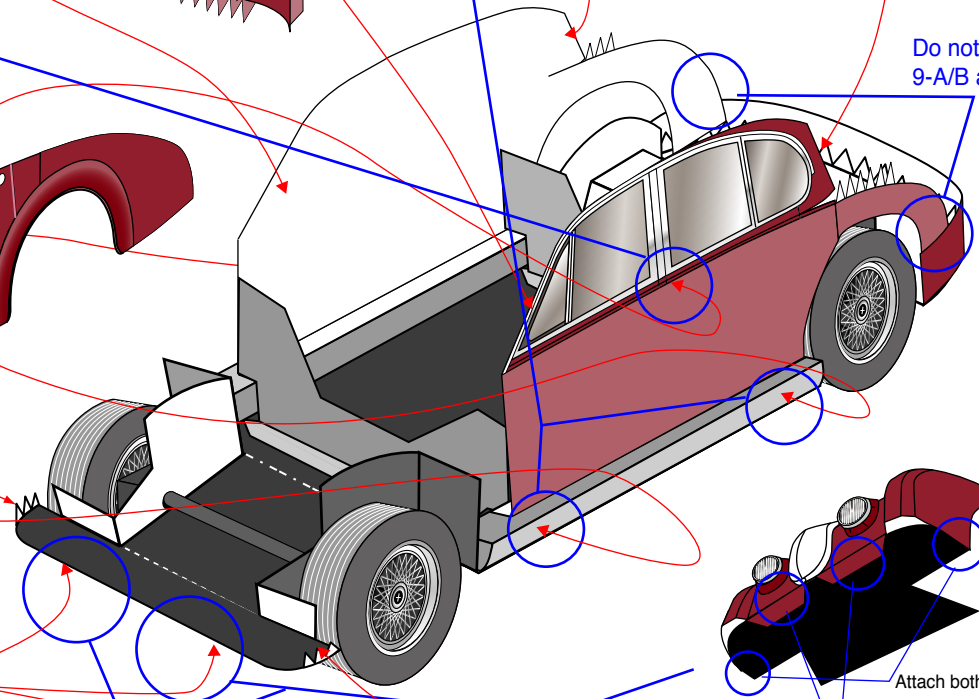
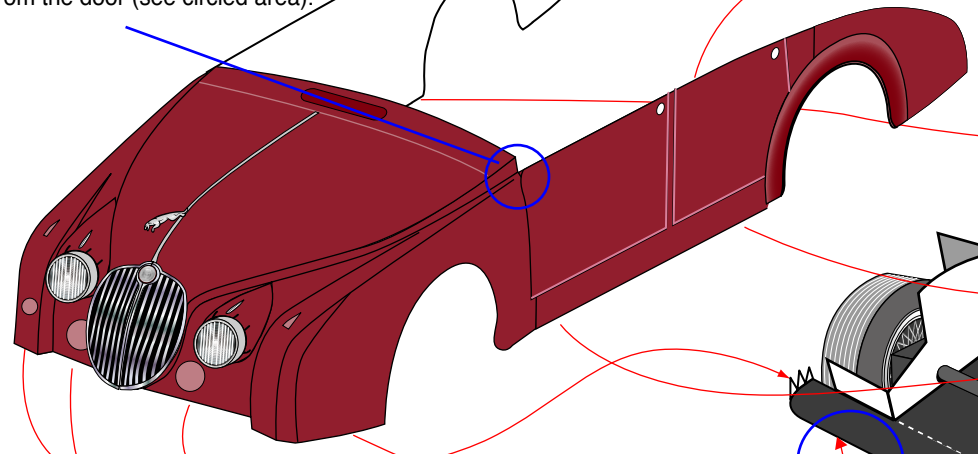

Attaching the head to 2-A should be done after attaching both sides.

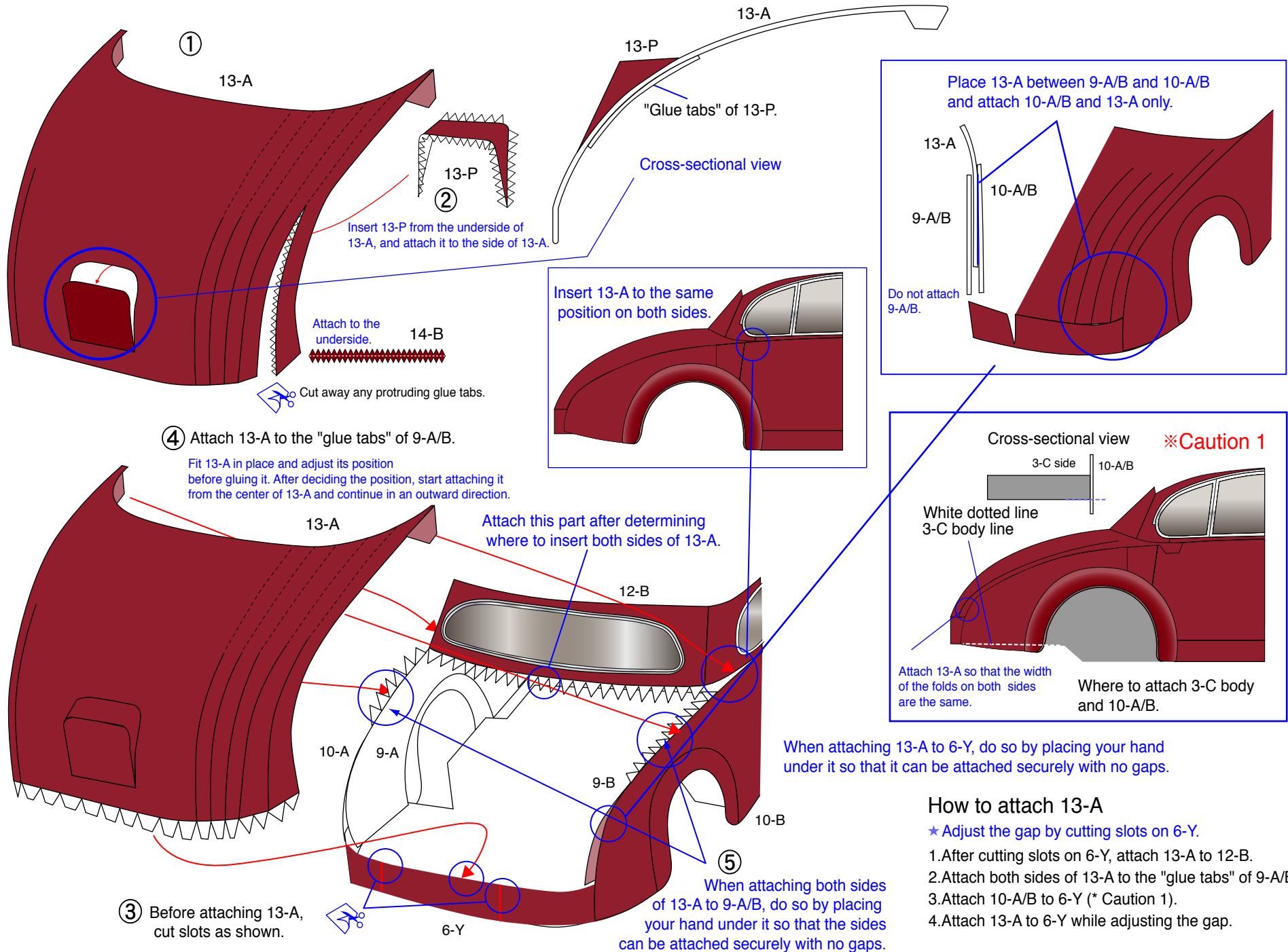

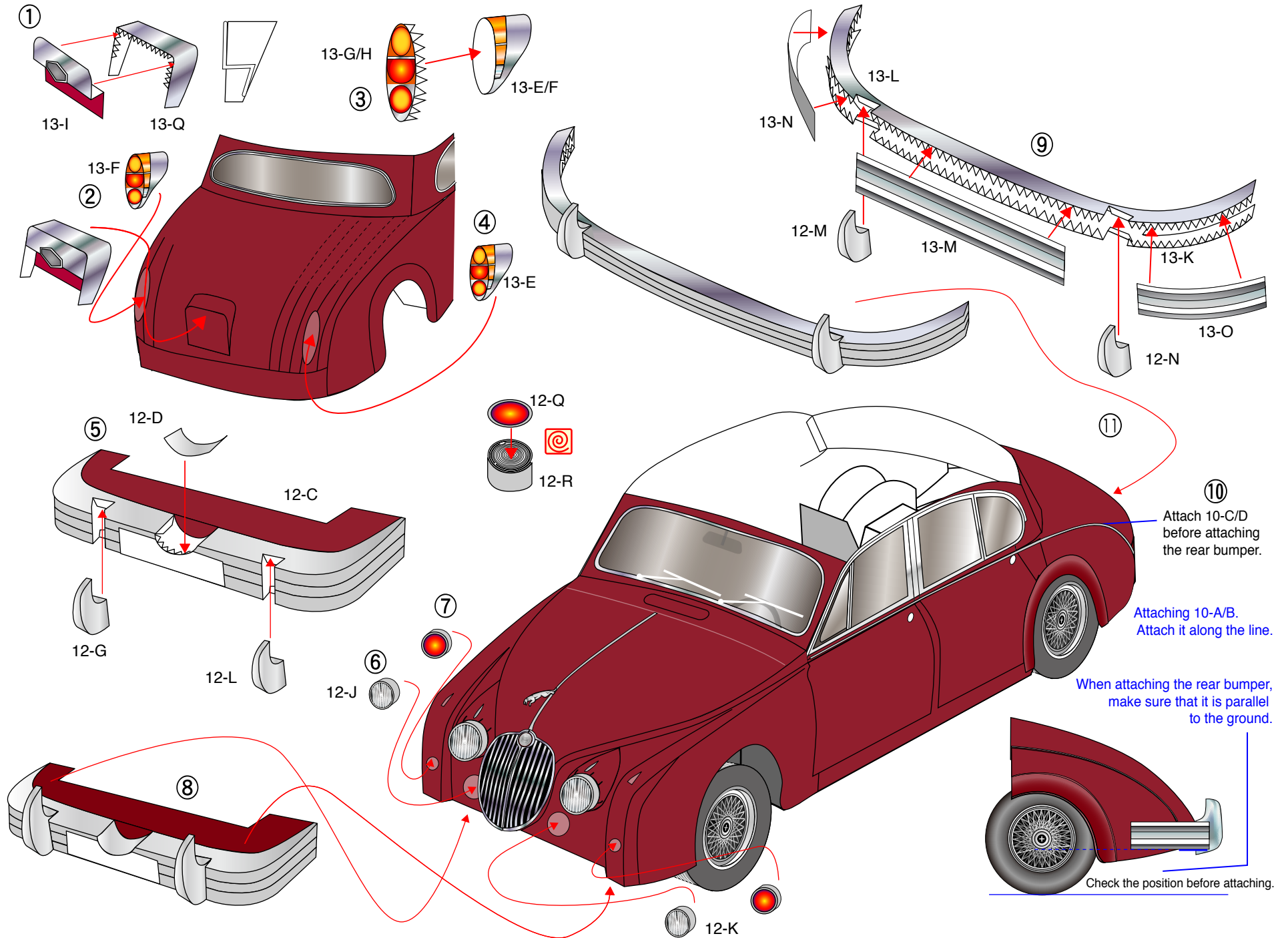

14-A
Attach the "glue tabs" of 14-B to the underside.

Attach 14-A in the following order: Attach the front part first, then the two sides, starting from the front and working back. Finally, attach the rear part securely.

Attach 14-A in the following order: Attach the front part first, then the two sides, starting from the front and working back. Finally, attach the rear part securely.

① Before attaching the "glue tabs" of 14-B to 14-A, attach them to 9-A/B and 12-A/B.

⑨ Make a mountain fold on 13-B/C and attach it together. Next, make a valley fold along the fold line as shown.

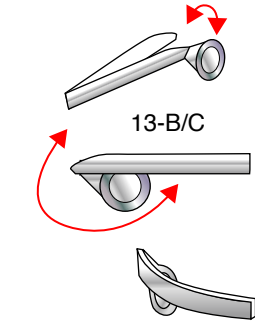

Bend 13-B/C while it is still damp so that it will dry curved.

Attach 13-B to the 10-A side, and 13-C to the 10-B side.

